



DEARBORN
LIVE POWER TAKE-OFF
MODEL 23-12



INSTALLATION AND OPERATING INSTRUCTIONS



Dearborn Live P.T.O. Attachment In Operation

The Live Power Take-Off Attachment, Model 23-12, is a hydraulically actuated unit designed for use in the Model NAA Ford Tractor. This attachment enables the operator to stop the forward or rearward motion of the tractor and implement while the tractor power take-off shaft continues to run and operate the P.T.O. driven implement. Without shifting gears or leaving the tractor, the operator can easily reduce slugging or plugging by moving the Live P.T.O. lever rearward, thus allowing the P.T.O. driven machine to clear itself before forward motion is resumed. It is most useful when operating P.T.O. driven corn pickers, corn harvesters and combines.

The Live P.T.O. Attachment replaces the tractor drive shaft and is located between the transmission and differential. The simple operation and smooth starting and stopping obtained by this attachment will greatly boost efficiency and help reduce wear on P.T.O. driven implements.

This manual contains information on the installation, general operation, and care of the Live P.T.O. Attachment. When installing the unit, read this manual carefully, study the illustrations, and always keep it available for ready reference.

DEARBORN MOTORS CORPORATION

BIRMINGHAM, MICHIGAN

www.ntractorclub.com

LIVE POWER TAKE-OFF

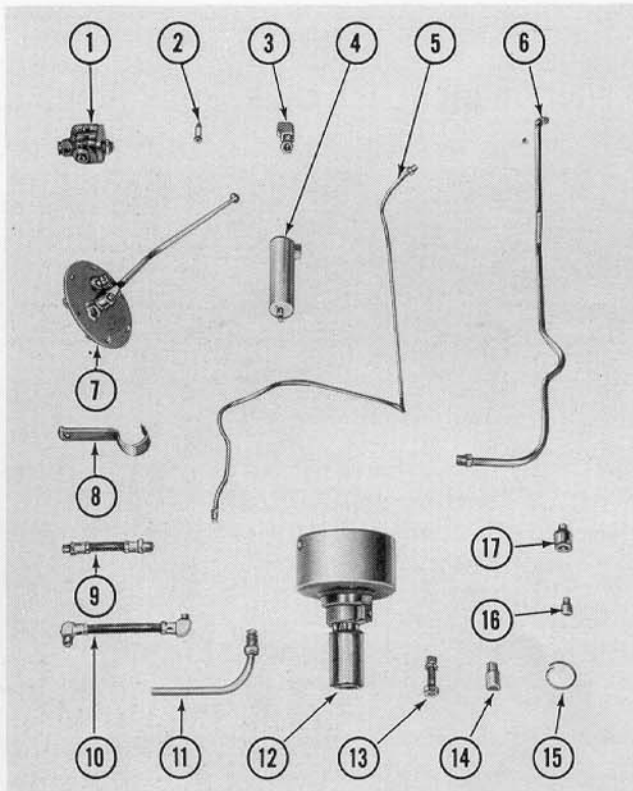

Figure 1

Dearborn Live P.T.O. Attachment Parts

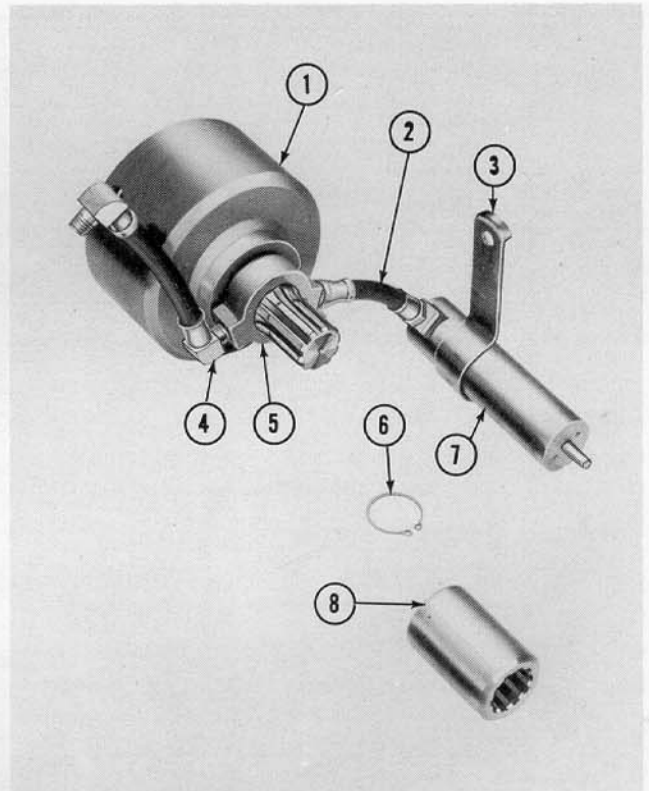

Figure 2

Clutch Assembly, Hoses and Accumulator

SHIPPING INFORMATION

The Dearborn Live P.T.O. Attachment is shipped in a carton (D.M.C. Bundle No. 23-12) which contains the parts shown in Figure 1. Check the contents of the carton against the following list and Figure 1, to be sure that all parts are received.

Item No.	Description	Required
1.	Hydraulic Pump, Gasket and Jam Nut Assembly	1
2.	Pump Drive Shaft and Aligner	1
3.	Bulkhead Elbow, Gasket and Jam Nut Assembly	1
4.	Accumulator Assembly	1
5.	Pressure Tube, 1/4"	1
6.	Supply Tube, 1/2"	1
7.	Control Valve Assembly	1
8.	Accumulator Bracket	1
9.	Hose Assembly—Clutch to Accumulator	1
10.	Hose Assembly—Clutch to Valve	1
11.	Suction Tube	1
12.	Clutch Assembly and Splined Coupling	1
13.	Bolt Assembly—Accumulator Bracket	1

Item No.	Description	Required
14.	Fitting—Supply Line to Pump	1
15.	Thrust Spring	1
16.	Fitting—Pressure Line to Pump	1
17.	P.T.O. Lever Extension	1

INSTALLATION PROCEDURE

NOTE: The installation of the Dearborn Live P.T.O. Attachment is the responsibility of the Ford Tractor and Dearborn Farm Equipment dealer. The attachment should be completely installed, checked and serviced before it is delivered. The dealer will show the purchaser how to operate the attachment and answer any questions as to its operation.

1. Open the shipping carton and account for the parts shown in Figure 1, to facilitate assembly and installation.
2. Prepare the tractor for the installation as follows:
 - a. Drain the oil from the hydraulic reservoir.

NOTE: Removal of the power take-off shaft assembly is not necessary, but will facilitate the re-assembly of the tractor. Before removing the shaft, drain the oil from the differential reservoir.

LIVE POWER TAKE-OFF

- b. Remove the hydraulic oil lines, step plates, and side covers from the tractor.
- c. Disconnect the left brake linkage and exhaust pipe bracket.
- d. Separate the tractor at the center housing and remove the drive shaft assembly.

NOTE: The Live Power Take-Off Attachment is partially assembled at the factory and the following step is provided in case of need. Before installation, check all fittings to be sure they are tight.

3. Assemble the clutch assembly, hoses, accumulator and accumulator bracket as follows:
 - a. Remove the splined drive coupling (8), Figure 2, and snap ring (6) from the clutch assembly (1).
 - b. Slide the collar (5), Figure 2, off the splined shaft and attach the hoses (2) and (4), to the tapped flanges on the collar. Make sure that the flanges of the collar are pointing downward as shown. Connect the hose (2), Figure 2, to the accumulator (7) as shown.

CAUTION: *Extreme care must be taken to avoid stripping*

the threaded brass connections. They should be tightened approximately one and one half turns beyond finger tight.

- c. Position the collar on the splined shaft as shown in Figure 2, and replace the snap ring (6) and drive coupling (8).
 - d. Slide the accumulator bracket (3), Figure 2, on the accumulator (7) so that it is in an upright position.
4. Install this sub-assembly in the tractor center housing with the splines of the drive coupling (8), Figure 2, engaged with those on the pinion shaft. (See Figure 4). The accumulator and bracket should be against the right side of the center housing as viewed from the rear. Secure the accumulator bracket to the lower front side cover hole with the $\frac{7}{16} \times 2\frac{1}{8}$ inch bolt, lockwasher and nut provided. Insert this bolt from the left hand side of the tractor so that the threaded portion, lockwasher and nut are outside of the tractor housing.
 5. Drill a $1\frac{3}{32}$ inch hole in the right side cover for the installation of the brass bulkhead fitting and

Figure 3
Right Side Cover Drawing

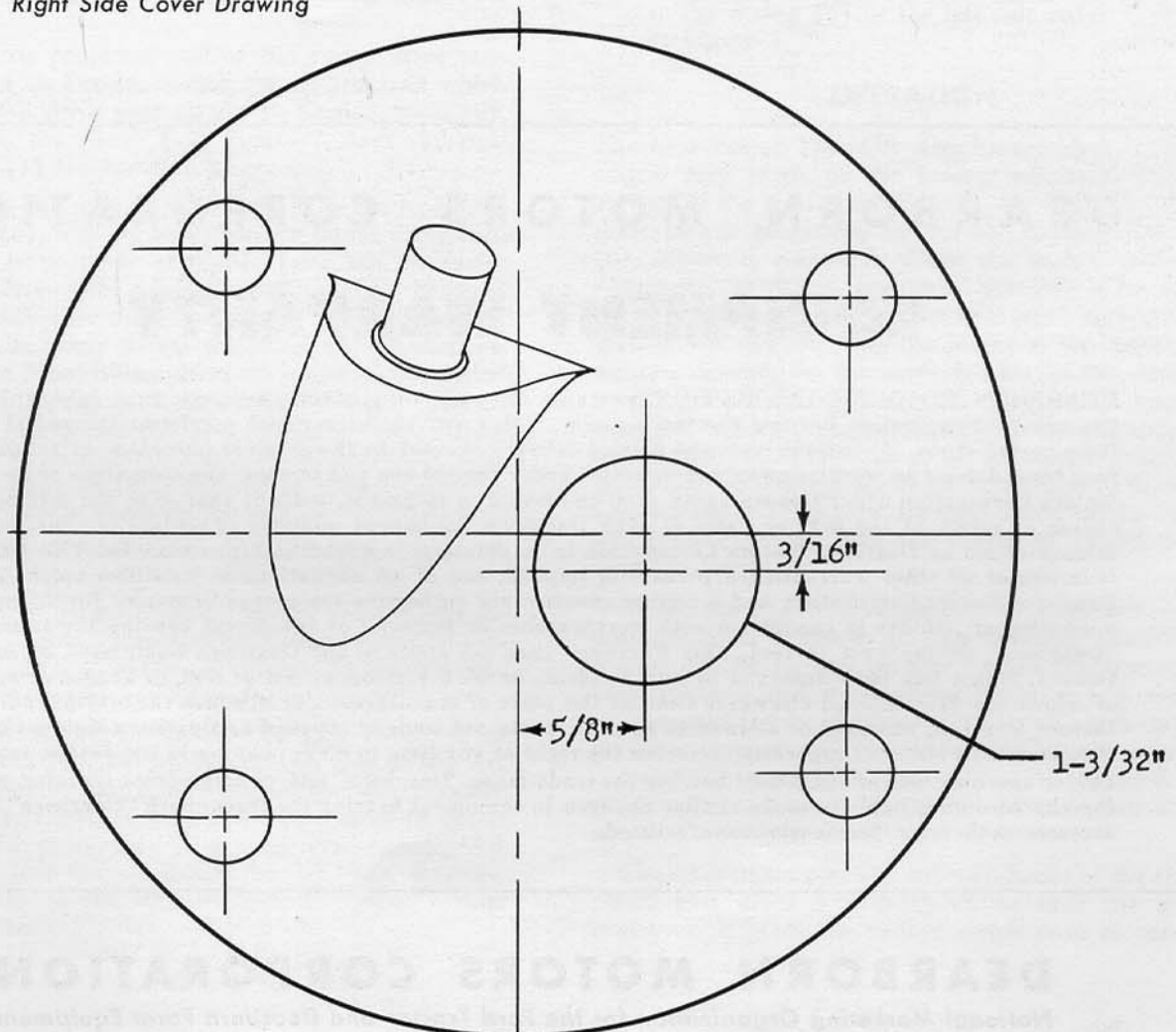

LIVE POWER TAKE-OFF

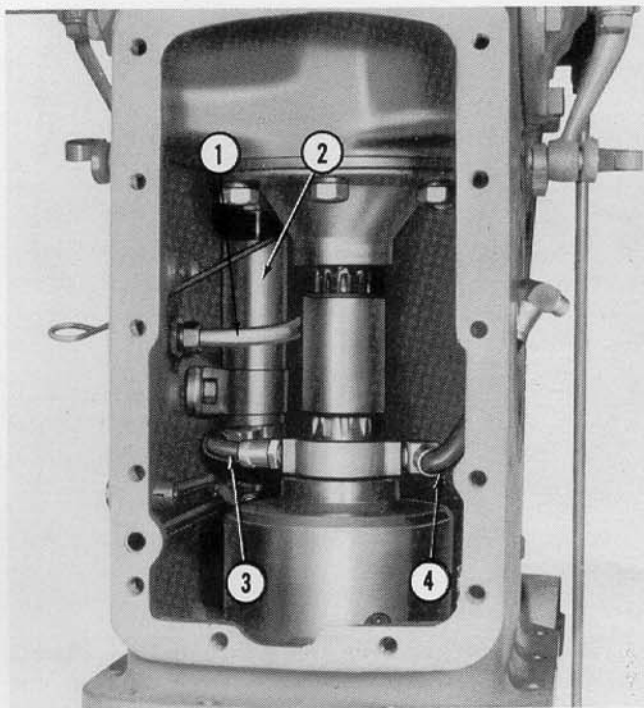

Figure 4
Clutch Assembly Installed

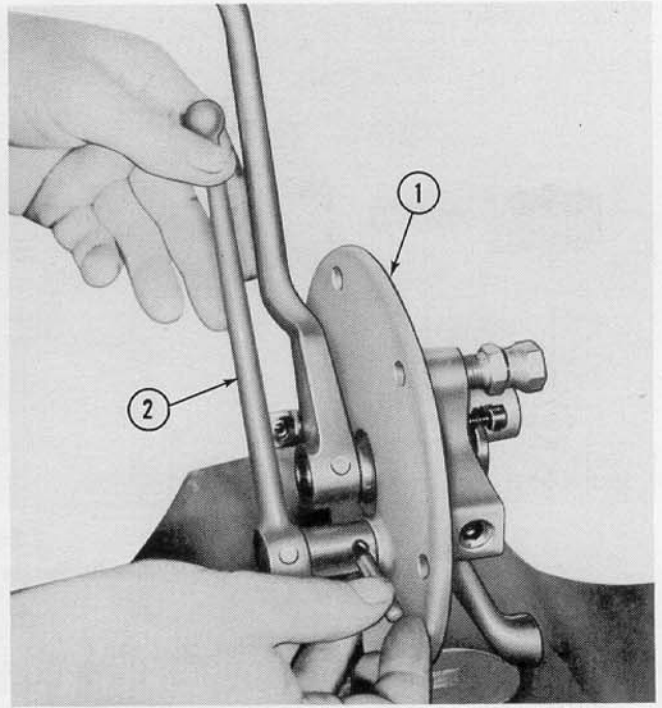

Figure 5
Shifter Lever Attached

suction pipe. To do this, cut Figure 3 from the instructions and use it as a template to locate the position of the hole to be drilled.

6. Place a gasket on the inner surface of the plate around the hole and position the brass bulkhead fitting in the cover with the outer opening upward. Secure with the jam nut provided on the inner side of the cover.

7. Place a new gasket on the side cover and attach the side cover assembly to the tractor with the suction pipe (1) positioned as shown in Figure 4.

NOTE: The hydraulic lift cover has been removed for illustration purposes in Figure 4. It is not necessary to remove the cover to install the Live P.T.O. Attachment. Care should be taken to see that the suction pipe (1), Figure 4, accumulator (2), and hoses (3) and (4) are positioned as shown.

8. Place the thrust spring (15), Figure 1, on the transmission main shaft and re-assemble the tractor. Do not install the tractor hydraulic oil lines at this time.

9. Remove the lever (2), Figure 5, from the original left side cover and secure it to the extension collar with the grooved pin provided. Attach this assembly to the valve and side cover assembly (1), Figure 5, as shown with a grooved pin.

10. Install the new gasket and attach the hose (1), Figure 6, to the swivel nut (2) on the left hand cover. Be sure that the hose is not twisted when the cover is in place. Bolt the cover to the tractor

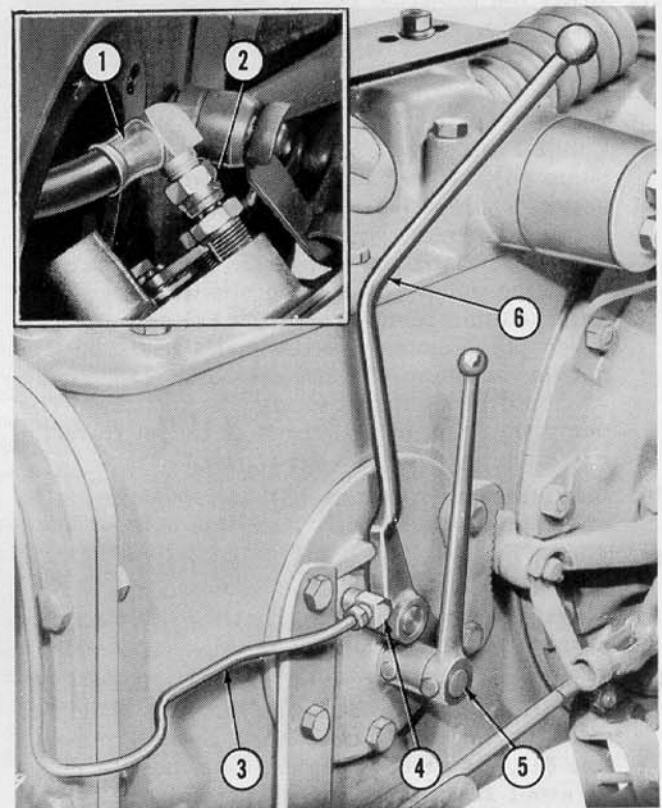

Figure 6
Left Side Cover Attached

LIVE POWER TAKE-OFF

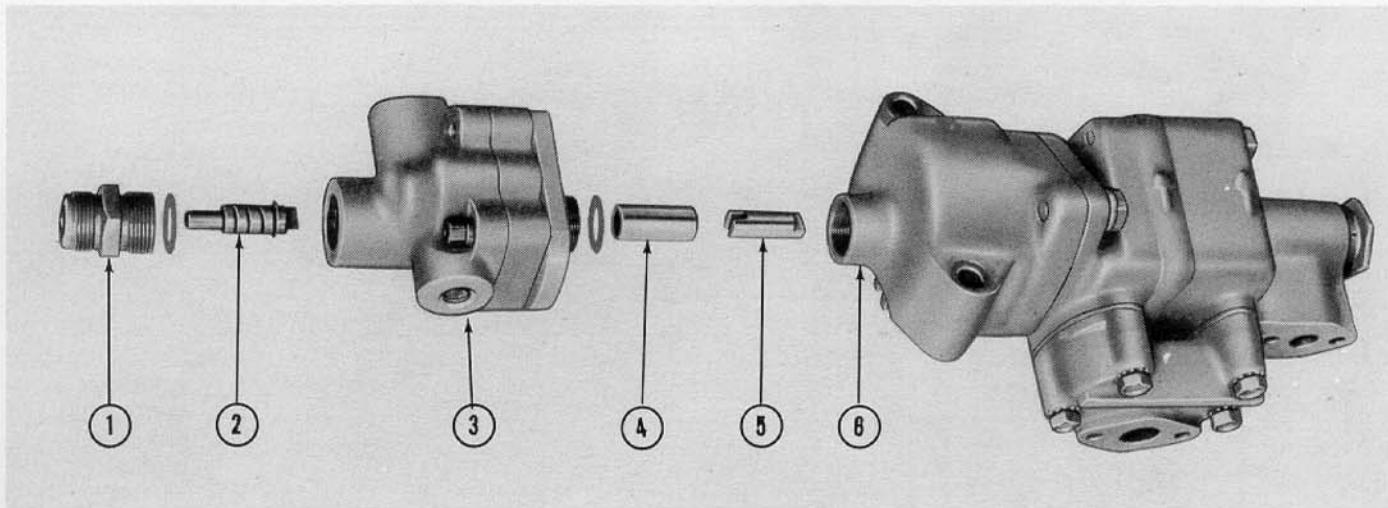

Figure 7
Hydraulic Pumps and Shaft Extensions

as shown in Figure 6. Make sure that the P.T.O. shifter lever arm (5) is engaged in the P.T.O. shifter rail.

11. Disconnect the Proof Meter cable and drive assembly (2), Figure 7, from the tractor hydraulic pump assembly (6) and remove the pump from the tractor.
12. Insert the projected end of the pump drive connector (5), Figure 7, into the slotted bolt which holds the drive gear on the hydraulic pump (6). Position the sleeve (4), Figure 7, over the connector (5) for constant alignment.
13. Connect the pump (3), Figure 7, to the hydraulic pump (6), making sure that the pump drive connector is properly engaged. Turn the hydraulic pump drive gear while connecting the pumps to make sure that the Proof-Meter drive is turning. If so, the pump drives are properly engaged. Install the Proof-Meter drive shaft (2) and threaded collar (1), Figure 7, in the pump (3). The jam nut on the pump (3) and the collar (1), Figure 7, should be tightened securely at this time. The pumps must be in alignment as shown to facilitate mounting them on the tractor.
14. Insert the brass fittings (3) and (4), Figure 8, in the pump.
15. Attach the pump assembly to the tractor and install the Proof-Meter drive cable in the Proof-Meter drive as shown in Figure 8. Replace the tractor hydraulic oil lines.
16. Connect the high pressure line (2), Figure 8, to the fitting (3). Do not attach this line to the left side cover at this time. Connect the low pressure line (1), Figure 8, as shown. Care must be taken to avoid cross threading these connections. All suction line fittings should be tightened securely, as a leak in the suction lines will cause erratic operation.

17. Replace the hydraulic and differential oil. Place a drip pan under the tractor to catch oil from the high pressure line. Start and idle the tractor to bleed all air from the hydraulic system. When a steady flow of air-free oil is obtained, stop the tractor engine and attach the high pressure line (3) to the fitting (4) in the left side cover as shown in Figure 6.

OPERATION

The Live Power Take-Off Attachment lever is located within easy reach of the tractor operator. Forward motion of the tractor can be stopped, while the P.T.O. shaft power continues, by merely moving the lever (6), Figure 6, rearward. When the lever is moved to disengage the clutch, hydraulic pressure is no longer applied to the clutch assembly, thus allowing the clutch discs to separate and stop the power to the tractor rear wheels. As long as the lever is held in the rearward position, the clutch will be disengaged. To start the tractor in motion, engage the clutch by releasing the lever gently, as in the case of a foot clutch. Feathering the clutch or holding the lever back slightly to obtain a very slow start or slow forward speed of the tractor will cause excessive heat and therefore should not be used too frequently.

When the engine is stopped, 2 to 3 seconds are required for the clutch to go into "lock-up" so that the tractor can be parked in gear. After the tractor has been stopped and it is started again, a few seconds are required for the clutch to come out of "lock-up" and go into engagement. The slower the tractor engine is running the longer this time will be. At engine R.P.M. (1500) this time will be about 3 seconds, but at idle speeds it may be as much as 10 seconds.

The attachment operates independently of the tractor clutch and when it is necessary to shift the tractor transmission gears, the engine clutch must be used.